

FIBER OPTIC SENSORS - GENERAL DESCRIPTION



Fiber optic sensors function electronically like any other photoelectric sensor with the difference that the light emitted and received is transported by an optical fiber the end of which is very small and in different forms and it can be installed some distance from the electronic circuit.

The reduced dimension of the fiber allows the sensing of very small objects and their installation in areas where other sensors would not fit.

Furthermore they can be used in explosion risk areas as well as in liquids and have a very high resistance to mechanical damage and to vibrations which makes them suitable for installation on machinery where movement is involved.

They are available in the reflection and barrier emitter/receiver.

The light source is red and the length of the standard fibers is 2 metres.

TYPES

FT18M-CFR WITH FIBERS FOR DIRECT REFLECTION

In this type of function the red light emitter and receiver are contained in one fiber (MULTI CORED) or side by side (DOUBLE CORED).

The sensing is obtained by the reflection of the rays of the object to be detected. The parameters that influence the sensing distance are mainly the colour, the reflective or the roughness of the surface to be sensed.

The maximum sensing distances mentioned in the technical characteristics refer to results obtained with a piece of matt white paper dimension 10 x 10 cm.

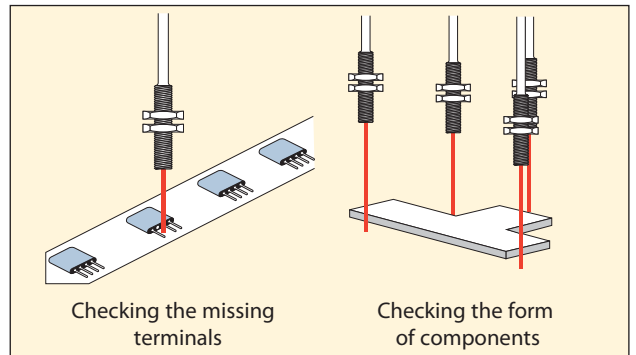
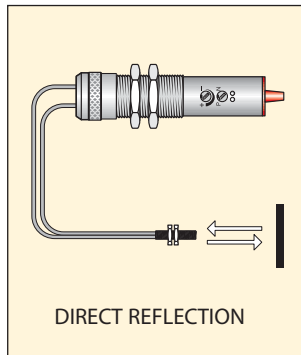

FT18M-CFR WITH BARRIER FIBERS EMITTER/RECEIVER

In this type of function the red light emitter and receiver are facing each other and are made up of a single fiber (SINGLE CORED).

Detection occurs when the rays emitted are interrupted furthermore these fibers can reach at their maximum sensitivity regulation, long distances as there is no dispersion between emitter and receiver. Their power can be increased by using the AT-4101 lenses.

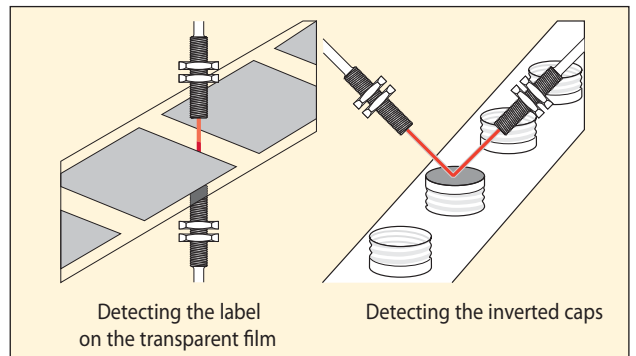
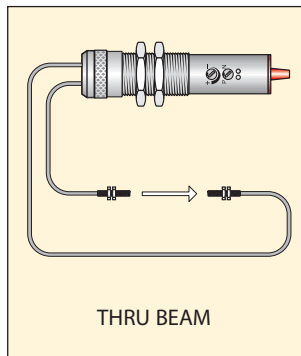

TECHNICAL CHARACTERISTICS

FT18M-CFR AMPLIFIER

- Easy to install by using the available accessories.
- Mechanically robust amplifier in AISI 303 stainless steel.
- Single amplifier for all detection systems.
- Single amplifier for NPN and PNP versions (selection by switch).
- Switch from NPN to PNP without variation in electrical connection.
- Antiphase NO+NC static output.
- Available with 2m cable or M12 H plug connector.

FIBER OPTICS

- Covered in plastic polythene.
- Temperature limits: -40 ÷ +70°C.
- Different types of fiber available.
- In various types it is possible to cut the fiber at the required length.
- Increased detection distance by using the AT-4101 lenses.
- Possibility of being able to divert the rays by 90° in the barrier types by using accessory AT-4102.
- Access in limited spaces with the types that have a sleeve.

FIBER OPTIC SENSORS - FT18M - CFR TYPES



STAINLESS STEEL CYLINDRICAL HOUSING M18 x 1
 PROGRAMMABLE OUTPUT NPN / PNP
 SENSITIVITY ADJUSTMENT
 FUNCTIONS NO + NC

TECHNICAL CHARACTERISTICS

Dimensions mm

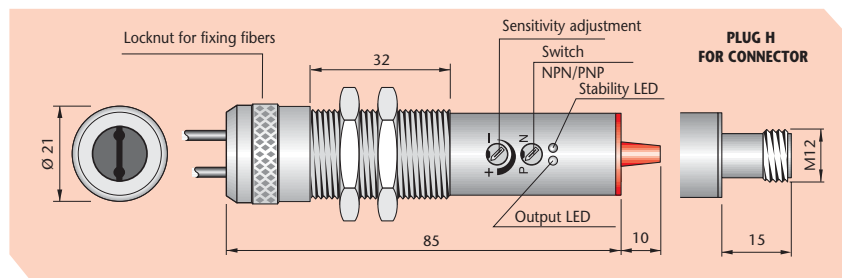

ONE TYPE FOR DIRECT REFLECTION OR THRU-BEAM

TYPE

MODEL WITH CABLE

FT18M-CFR

MODEL WITH H PLUG

FT18M-CFR-H

Programmable output		NPN/PNP	NO + NC
Light source	Led		Red
Power on delay	mSec		≤ 75
Switching frequency	Hz		700
Continuous voltage (Res. ripple ≤10%)	V		10 ÷ 30
Max output current	mA		200
Max current consumption at 24 Vdc	mA		≤ 50
Voltage drop (I out = 200 mA)	V		≤ 3
Short circuit protection			Incorporated
Light immunity			> 10.000 Lux
Led	Yellow		Operation indicator
	Green		Stability
Temperature limits	°C		Storage -20 ÷ +90°C • Working -20 ÷ +50°C
Protection degree	IP		65
Housing			Stainless steel AISI 303
Cable	2m		4 x 0.25 mm ²
Connector plug			H
Possible wiring connection			See page 69

WIRING DIAGRAMS

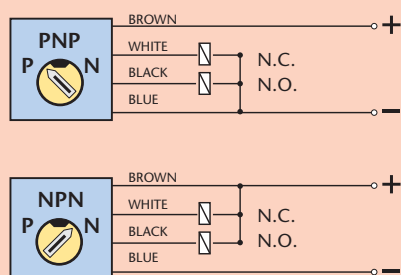

FT18M-CFR with direct reflection fiber
 BLACK WIRE = N.O. WHITE WIRE = N.C.

FT18M-CFR with thru-beam fiber
 BLACK WIRE = N.C. WHITE WIRE = N.O.

CONNECTION WHIT H PLUG FOR CONNECTORS SEE PAGE 85

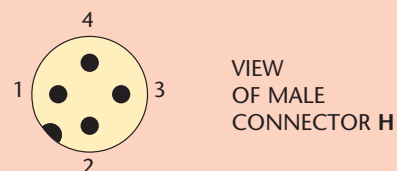

FT18M-CFR-H power supply
 1 = Positive 3 = Negative

FT18M-CFR-H with direct reflection fiber
 4 = NO 2 = NC

FT18M-CFR-H with thru-beam fiber
 4 = NC 2 = NO

PHOTOELECTRIC

FIBER PROBES FTL - FDL



	TYPE	DIMENSIONS mm	SENSING DISTANCE mm	APPLICATION	CUTTING	FIBER TYPE
THRU BEAM TYPES	FTL000*		150	STANDARD	POSSIBLE	SINGLE CORED
	FTL100*		150	STANDARD	POSSIBLE	SINGLE CORED
	FTL300*		150	STANDARD	POSSIBLE	SINGLE CORED
DIRECT REFLECTION TYPES	FDL010		60	STANDARD	POSSIBLE	DOUBLE CORED
	FDL020		60	POSITIONINGS	POSSIBLE	MULTI CORED
	FDL310		60	STANDARD	POSSIBLE	DOUBLE CORED
	FDL120		60	POSITIONINGS	NOT POSSIBLE	MULTI CORED
	FDL210		70	STANDARD	NOT POSSIBLE	DOUBLE CORED
	FDL311		10	DETECTING SMALL OBJECTS	NOT POSSIBLE	DOUBLE CORED

ACCESSORIES

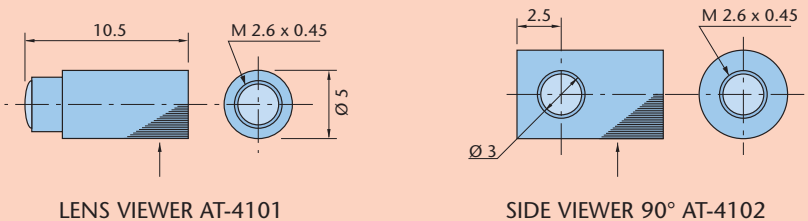

NOTE:

The two accessories can be used only with the following fiber: FTL100. The AT-4101 lens increases the standard distance by approximately 8 times if mounted on the emitter and receiver.

*Thru beam types are supplied emitter + receiver together.

FIBER OPTIC SENSORS - OPERATING PROCEDURES



INSTRUCTIONS FOR THE PROGRAMMING AND ADJUSTMENT

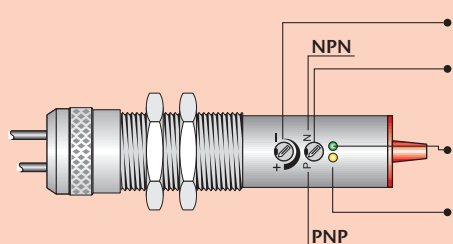

- **TRIMMER FOR THE SENSING RANGE ADJUSTMENT:** The photocell is supplied with max. sensing range with the trimmer totally rotated in the clockwise direction. The sensitivity reduces by rotating the trimmer in the anti-clockwise direction.
- **SWITCH NPN/PNP:** The photocell is supplied with the switch in P (PNP output). To change to NPN turn the switch to N in the anti-clockwise direction.
WARNING! For a correct working of the unit, do not carry out the switching when the photocell is powered.
- **GREEN LED - STABILITY INDICATOR:** This led is on when the level of the output signal and the alignment of the photoelectric sensors are in the optimum position. In the case that the led is off this indicates that the lens is obscured or for the types with direct reflection a possible alteration of the dimension or color of the object to be detected.
- **YELLOW LED - OPERATION INDICATOR:** This led is on when the object to be detected enters the sensing range of the photocell giving output signals.

N.B. SENSITIVITY ADJUSTMENT

- After adjustment the sensitivity can vary depending on variations in the object or conditions in the area of installation.
- As reflection varies in relation to the object, adjustment should be carried out with the object present.
- After having carried out adjustment, the fixing of the way and the curvature of the fiber should not be changed.

PROCEDURE FOR THE DIRECT REFLECTION FIBER OPTICS ADJUSTMENT:

Adjust the sensitivity to minimum turning the trimmer anticlockwise. Position the object to be sensed at the required distance in relation to the end of the fiber and turn the trimmer slowly clockwise until the yellow led lights up. Continue turning the trimmer until the green led lights up. Re-check that the calibration is correct by using the object and possibly by repeating the procedure.

IMPORTANT: in the presence of objects to be sensed the yellow led should be illuminated.

Output functions in the absence of the objects to be sensed.

NO output = black wire (H version = PIN 4)

NC output = white wire (H version = PIN 2)

PROCEDURE FOR THE THRU-BEAM FIBER OPTICS ADJUSTMENT:

Adjust the sensitivity to minimum turning the trimmer anticlockwise. Position the end of the fibers at the required distance and turn the trimmer slowly clockwise until the yellow led lights up. Continue turning the trimmer until the green led lights up. Re-check that the calibration is correct by using the object and possibly by repeating the procedure.

IMPORTANT: in the presence of objects to be sensed the yellow led should be illuminated.

Output functions in the absence of the objects to be sensed.

NC output = black wire (H version = PIN 4)

NO output = white wire (H version = PIN 2)

PROCEDURE FOR ASSEMBLING FIBERS IN THE FT18M-CFR

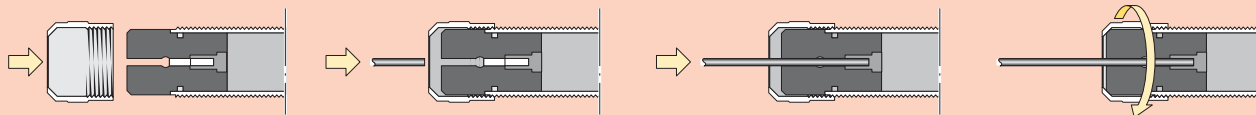

1) Position and screw the locknut in the sensor loosely.

2) With the locknut loose insert the fibers in the two receptacles.

3) With the locknut loose in the fibers ensuring that they reach the end.

4) Tighten the locknut carefully and ensure that, at the end of the operation, the fibers are blocked.

ACCESSORIES FOR MOUNTING AND INSTALLATION

MOUNTING BRACKET TYPE ST18

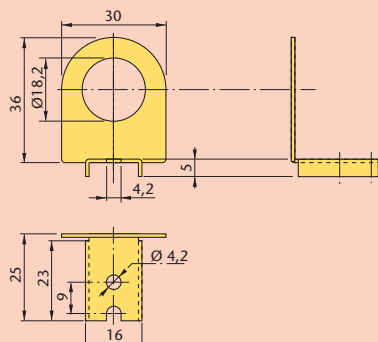

APPLICATION EXAMPLES WITH TYPE ST18

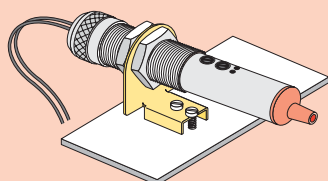

MOUNTING BRACKET TYPE ST3 FOR DIN RAIL MOUNTING

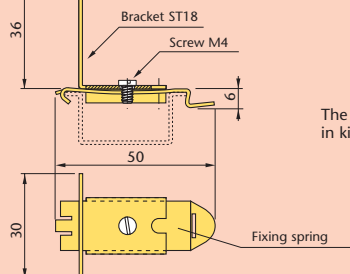

The mounting bracket ST3 is supplied in kit with ST18 + screw M4 + fixing spring.

APPLICATION EXAMPLES WITH TYPE ST3

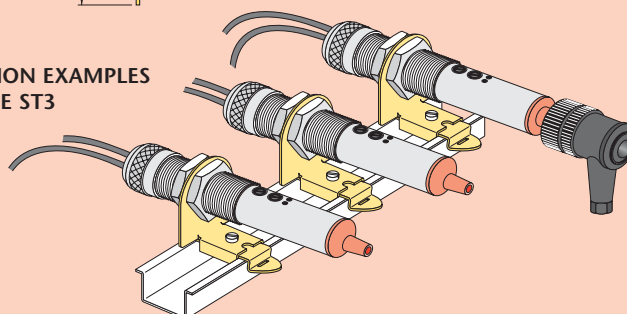

FIBER OPTIC SENSORS - NOTES AND CAUTIONS FOR CORRECT OPERATIONS



FIBER CUTTER AT 118

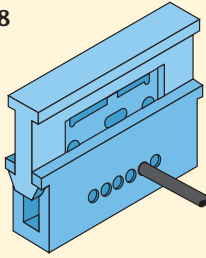

FIBER PROBES

Cutting-free type plastic fibers can be cut by the optional cutter (AT118) at any desired length

Cut the plastic fiber before connection. Make sure to cut it sharply since the status of cutting surface influences to the sensing distance which might be reduced by up to 20%.

Cutting should be done sharply by one action, and do not use the same hole more than once.

FIBER FIXING

Use the supplied spring lockwasher for fixing the fibers with threaded bushing in order not to damage the fibers with excessive force.

When fixing the non-threaded head type with a set-screw (M3 max.) as indicated on the left side scheme, apply a torque of 3 kgf/cm max.

CONNECTION OF DIRECT REFLECTION MULTI-CORED FIBER

Put the SINGLE-CORED fiber to the LIGHT-EMITTER side and the MULTI-CORED fiber to the RECEIVER side.

STAINLESS SLEEVE FIBERS

The fibers with this type of terminal are very useful when the installation is done in locations not easily accessible and this can be obtained bending the sleeve in relation to the required position.

Make the bending radius to be processed on anneals stainless sleeve on the sensing head as large as possible according to the sleeve diameter rate as indicated on the left side scheme.

TYPE	FIXING TORQUE
M 3	6 Kgf - cm MAX.
M 4	6 Kgf - cm MAX.
M 6	10 Kgf - cm MAX.

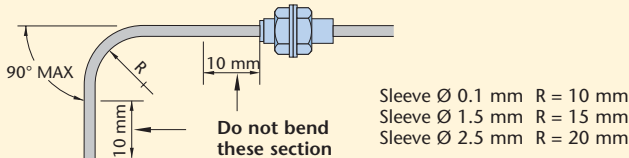
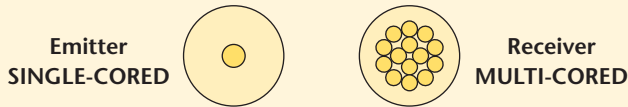
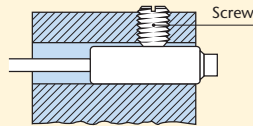

FIBER OPTIC - CHARACTERISTIC CURVES

TYPES FTL000 - FTL100 - FTL 300 (Thru beam)

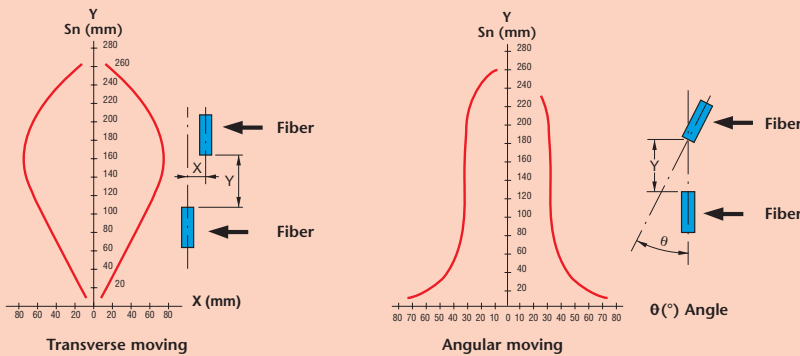

TYPES FDL 020 (Direct reflection)

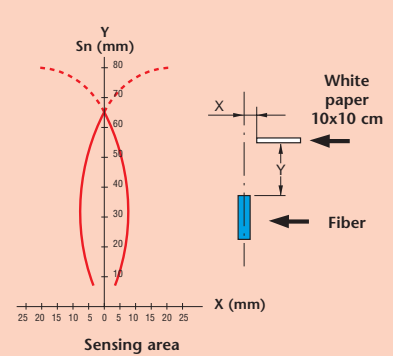

TYPES FDL010 - FDL310 (Direct reflection)

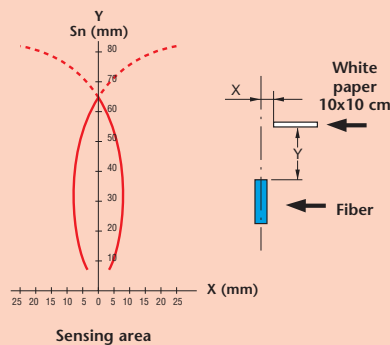

TYPES FDL311 (Direct reflection)

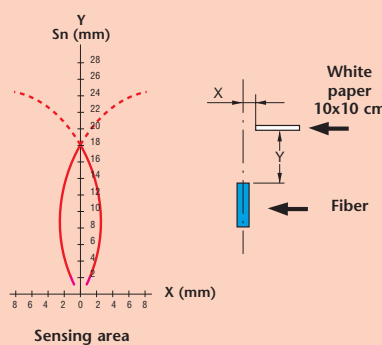

TYPES FDL210 - FDL120 (Direct reflection)

